

TOPFLEX

TWIN -SPHERE RUBBER EXPANSION JOINT

(With Floating Flanges)

TOPFLEX Series TT and PTT are ideal in heating and air conditioning system. Series TT and PTT are Twin-Sphere joint with EPDM cover and EPDM tube. It provides excellent resistance to ozone and sunlight aging and oxidation. The unit has an EPDM tube, which is good for hot and cold water service and chemicals. The Twin-Spherical design not only provides a high pressure rating, also provide greater flexibility, thus protecting mating flanges, especially PVC and fiberglass types. The steel flanges easily rotate on the bellows which makes it easier to line up the bolt holes during installation when mating flanges are out of line. Flanges are of galvanised steel with a steel bead (flange retainer). Standard size range from 1.1/2" to 12" I.D., with operating pressure at 300 psi and size 14" to 24" with operating pressure at 150 psi at -20°C to 100°C

BILL OF MATERIALS

ITEM NO.	DESCRIPTION	MATERIAL
1	Flange	Mild Steel / Stainless Steel
2	Wire	Carbon Steel Wire
3	Elastomer	Synthetic Rubber (EPDM)
4	Reinforcing Fabric	Nylon cord fabric

* Optional Material Flange : Stainless Steel

TECHNICAL CONDITION

Model	TT	PTT
Size I.D.	1.1/2" -12"	14" -24"
Working pressure	300 PSI	228 PSI
Burst pressure	854 PSI	580 PSI
Vacuum Rating	650 mm/Hg	
Temperature	-20°C to 100°C	

Installed with control rods to prevent internal pressure and motion by over limit usage and vacuum dropping. Control rods and reinforcing ring unit must be installed when pressure (test surge, operating, Starting a pump, etc.) exceeds the rating.

Allowable Movements

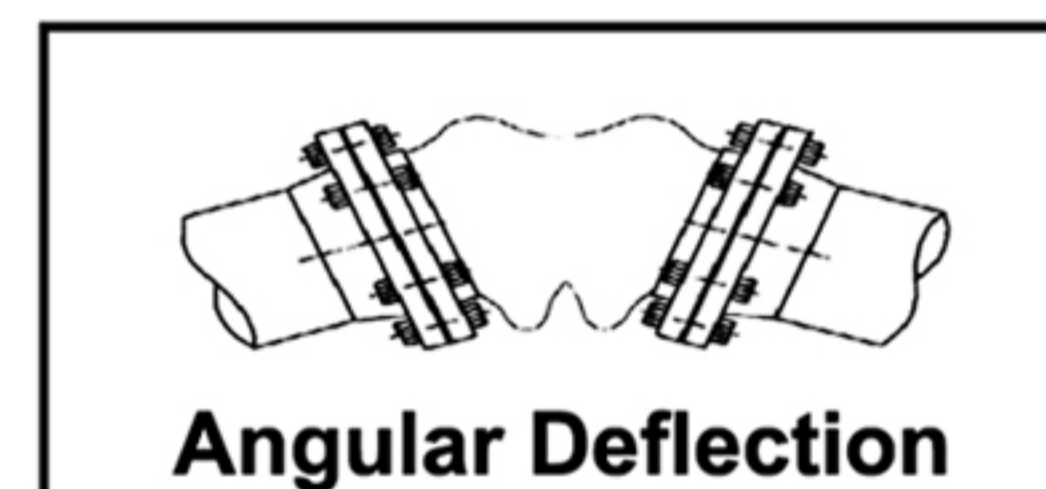
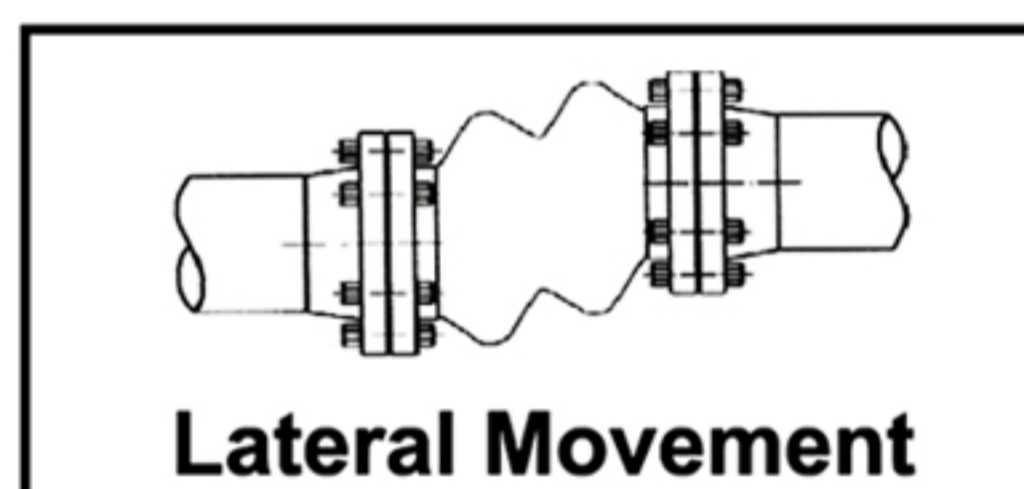
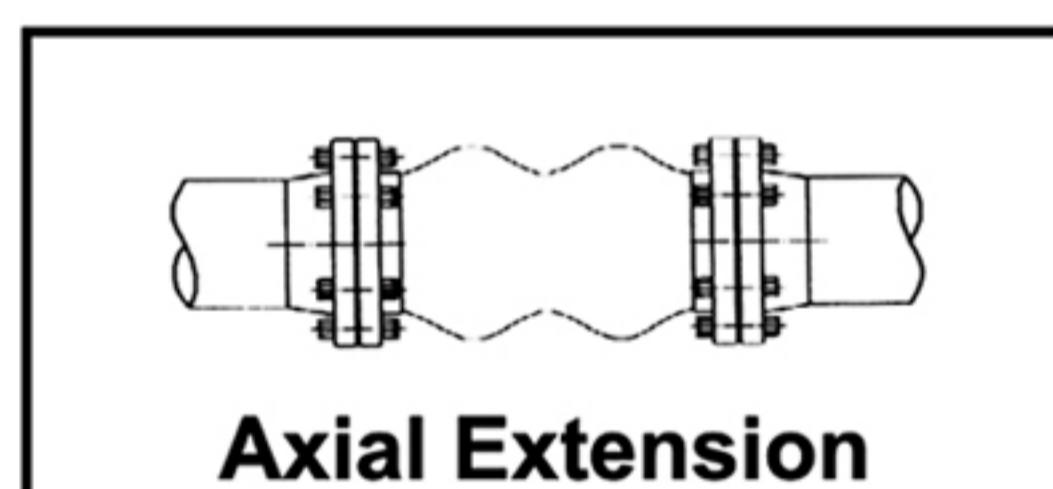
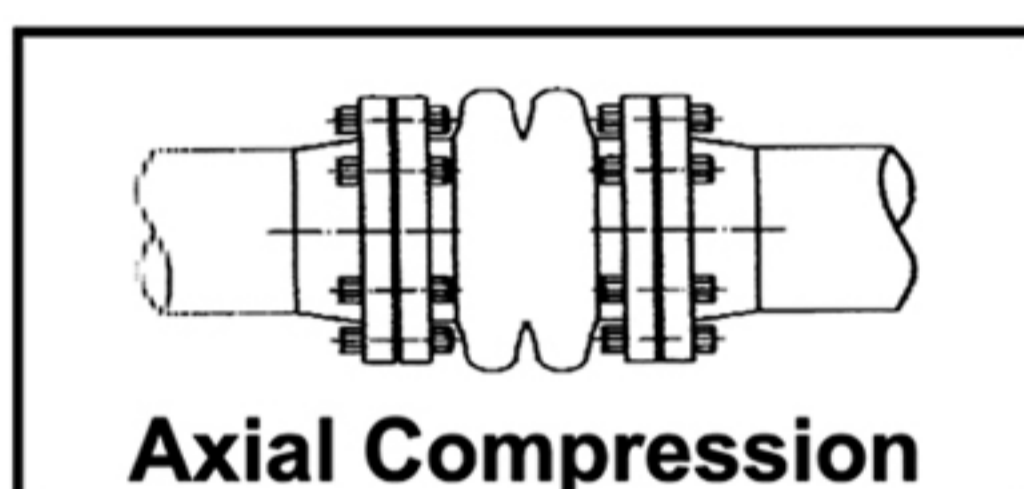

Table of Main Parameters of Normal Core Diameter, Length, Displacement Value

Normal core diameter		Length (L) (mm)	Axial displacement		Lateral (mm)	Angular
(mm)	(in.)		Compression (mm)	Extension (mm)		
40	(1.1/2)	175	50	30	45	35°
50	(2)	175	50	30	45	35°
65	(2.1/2)	175	50	30	45	35°
80	(3)	175	50	30	45	35°
100	(4)	225	50	35	40	35°
125	(5)	225	50	35	40	35°
150	(6)	225	50	35	40	35°
200	(8)	325	60	35	35	30°
250	(10)	325	60	35	35	30°
300	(12)	325	60	35	35	30°
350	(14)	350	50	40	30	20°
400	(16)	350	50	40	30	20°
450	(18)	350	50	40	30	20°
500	(20)	350	50	40	30	20°
600	(24)	350	50	40	30	20°

NOTE :

- Standard material is EPDM. The products are not applicable to oil. Other kinds of rubber material are optional.
- Standard rated working pressure are 16 bars and 20 bars (up to 300 mm.) to 10 bars (for larger size than 300 mm.)
- Applicable fluids : Air, Compressed air, water, sea water, hot water, weak acid, alkalis, etc.
- Flange drilling : JIS, DIN, ANSI, BS and other standard drilling for your specification.



1. Flange
2. Wire
3. Elastomer
4. Reinforcing Fabric

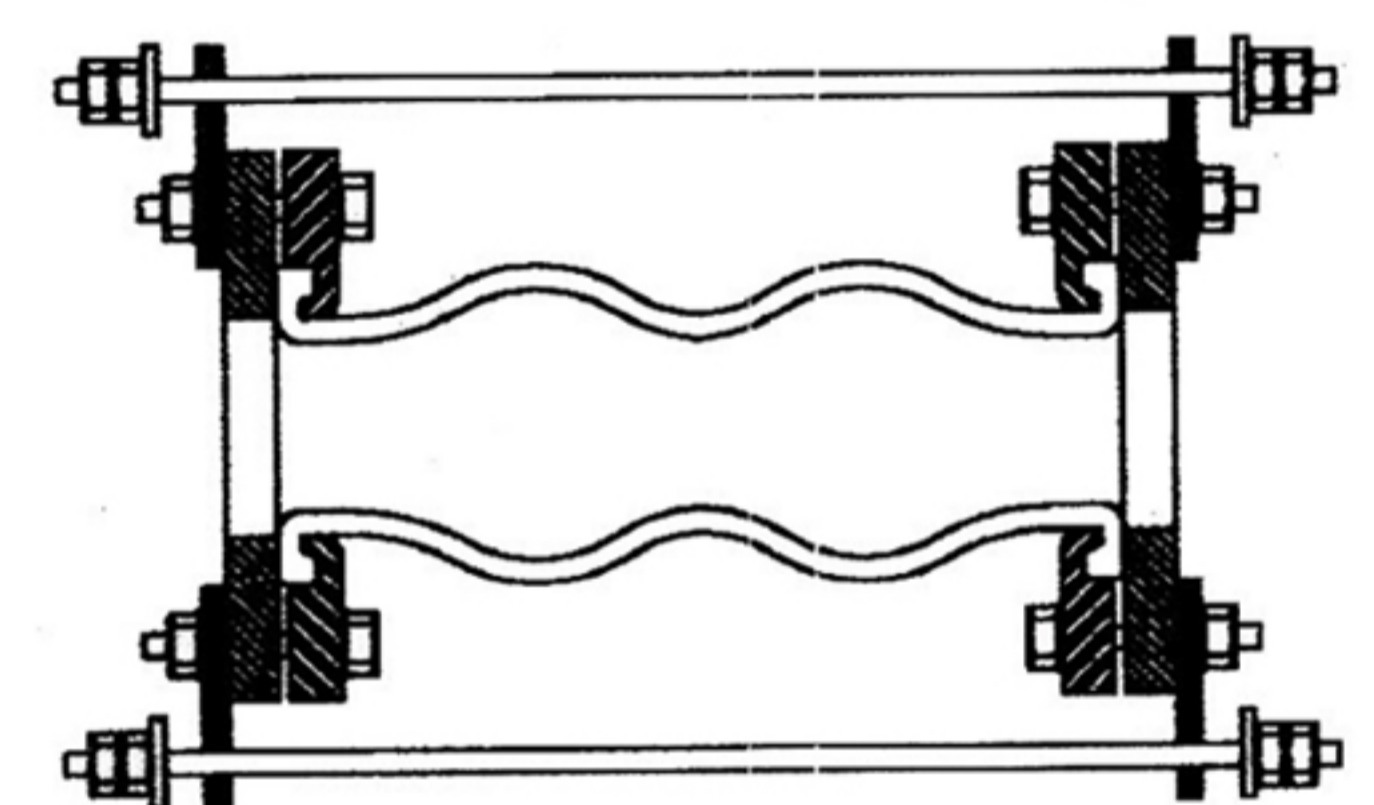
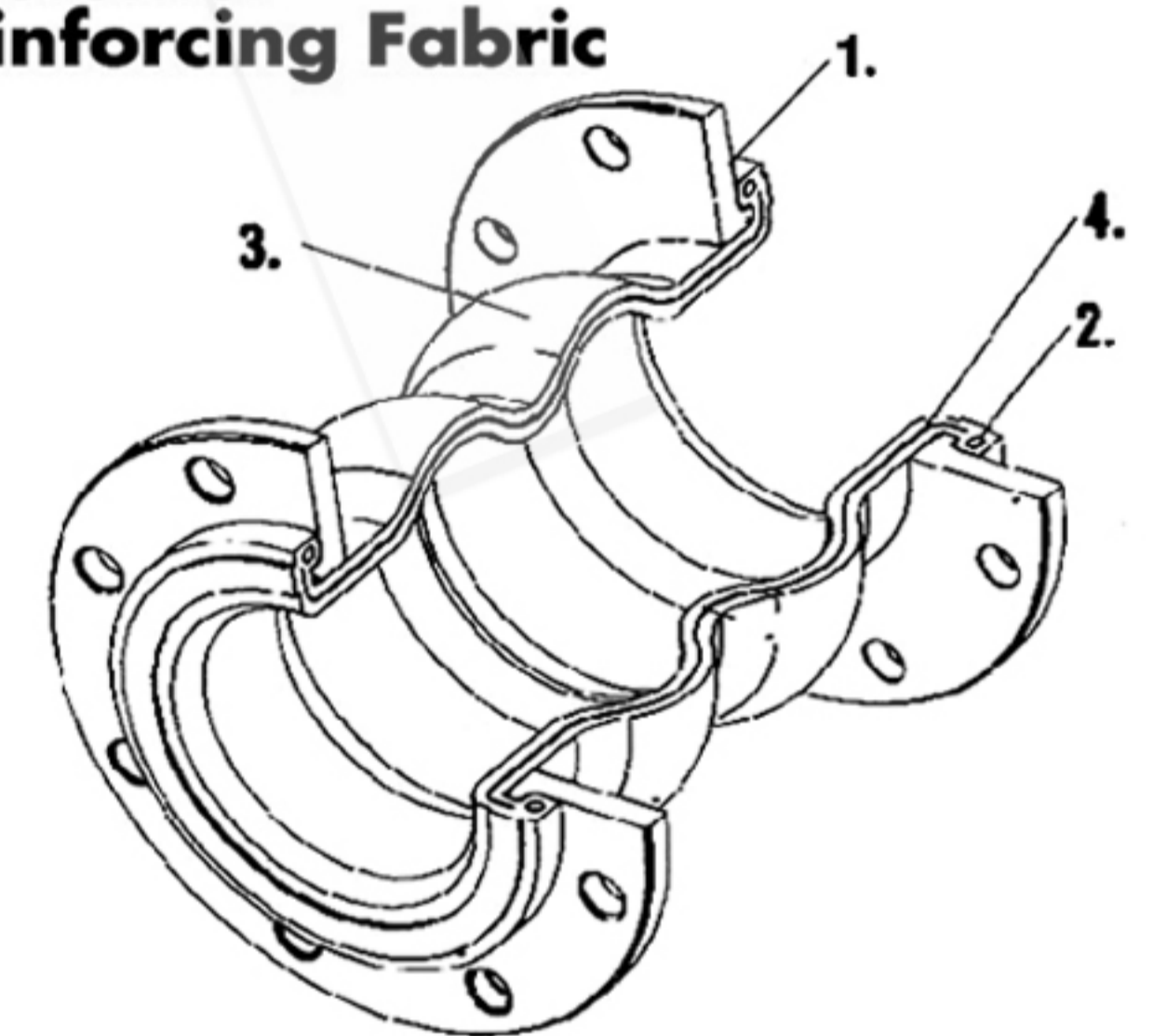

WITH CONTROL RODS